

Cold storage technology
for the pharmaceutical industry and for research



ANGELANTONI: a name, a story...

Giuseppe Angelantoni



When **Giuseppe Angelantoni** founded his business in the cold storage technique in 1932, he probably could not even have imagined that, years later, his very surname would have become a synonym for “cold storage engineering”.

His ingenious work has passed through significant cold technology applications, some of which are patented, such as: the first test chamber at -60°C in 1954; the first autonomous vehicle-driven food transport system in 1956; the first freezer in Europe at -104°C in 1961 with mechanical cooling, without LN2.

The story of his life coincides with that of the companies founded as a result of his prolific activities, which today are present in 3 business fields under **Angelantoni Industrie (Holding)**.

- 1) Refrigeration equipment and installations for hospitals, universities, research laboratories and chemical-pharmaceutical industry (**Angelantoni Life Science - ALS**);
- 2) Environmental simulation chambers and thin-film coating technology (**Angelantoni Test Technologies - ATT and Kenosistec**);
- 3) Renewable energy and energy efficiency (**Archimede Solar Energy and Turboalgor**).

Double stage refrigeration compressor patented in 1949



Refrigerated Truck, 1957

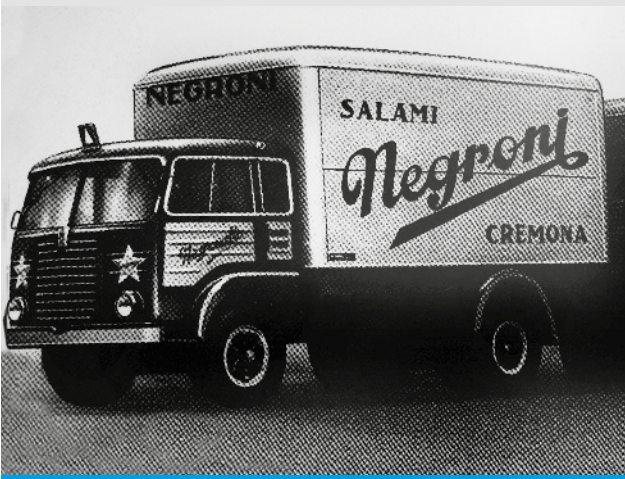

Refrigerator -104°C , 1962

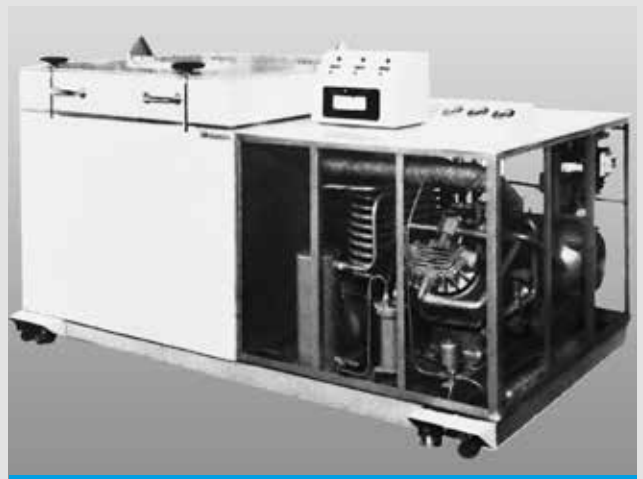

...a reality, a future

The quality system of Angelantoni Industrie is certified in accordance with standards ISO 9001, ISO 14001, ISO 13485.

This brochure is intended to briefly outline the activity of cold technology applied to various industrial sectors, in particular the pharmaceutical industry, by means of the following illustrations. In this sector, processes pose technological challenges due to the extremely low temperatures involved and the ensuing design choices, together with a need for extreme reliability due to the critical nature of the values of those processes.

Angelantoni Life Science has collected the heritage of the **AG** Division of Milan, today merged into the site in Massa Martana, taking advantage of the experience they have gained over 80 years of work with the related developed skills.

Therefore **ALS** is capable of offering the best solutions with a high degree of reliability proven by the many references with major national and international companies in the industry.

"Lab Automation" production area for robotic refrigerators



Custom design chilling units

The competences and experience which the AG Division of Milan has given us allow us to design and manufacture custom-made chilling units, according to the specific requirements of the Customer. Safe, eco-friendly and efficient installations, equipped with modern safety systems, low environmental impact and considerably higher efficiency than old generation installations (R507/R404A).

Main features

- Heat output: from **10** to **2,000** kW
- Working temperature: from **20°C** to **-80°C**
- Executions for **classified** or **safe area**
- Compliance with the **main international design and construction principles** (PED - GMP - ASME - ANSI, etc.)
- Multidisciplinary **design** (mechanical, electric and instrumental) both in the preliminary design stage and in the execution stage
- Project management, supplier control and testing during installation

Refrigeration system for the production of antibiotics



Brine package chilling units down to -75°C cascade system, equipped with pumps and liquid tank.
Refrigeration system for the production of antibiotics.



Package units for cascade system, 40 kW capacity at -80°C , condensing with glycol water at -25°C , 3 independent circuits.
Refrigeration system for the production of antibiotics.



Brine package chilling units down to 30°C with 3 independent circuits equipped with pumps and liquid tank.
Refrigeration system for the production of blood-derivative drugs.



For over 80 years, Angelantoni has been designing and building a large variety of refrigeration systems, especially intended for the chemical and pharmaceutical industry, with the support of professionals with longtime experience in the design and supply of refrigeration systems for Italian and international customers.

All installations are equipped with automatic control and monitoring systems of the operating conditions. Alarm systems, with possible redundancy, to meet the strictest reliability requirements.

The alarms triggered by the system can be transmitted to the control room via text messages or e-mail.

The AG Division of Milan in particular has provided us with competences for the standardised production of monobloc brine chilling units (mixture of water and ethylene or NaCl2 glycol) down to -30°C .

The standard chilling units can also be supplied in versions for temperatures down to -50°C with double stage or screw compressors using suitable brine liquids.



Cold technologies for industry

Prefabricated refrigerated warehouses for the chemical and pharmaceutical industry



Prefabricated cold storage room with 150 mm thick panels plasticised inside and outside. Outer dimensions: m 40.50 (L) x 8.00 (W) x 10.20 (H) Sliding doors 2m (W) x 3m (H) net clearance, automatic opening, with safety closure. Operating temperature -20°C .

Prefabricated cold storage room with 100 mm thick panels plasticised inside and outside. Outer dimensions: m 28.00 (L) x 11.6 (W) x 8.5 (H) Sliding doors 2.00m (W) x 2.5m (H) net clearance, automatic opening, with safety closure. Operating temperature $+2^{\circ}\text{C}$.



PE Series Prefabricated cold rooms

Angelantoni Life Science manufactures a wide range of cold storage rooms used to preserve vaccines, drugs and other products for the pharmaceutical healthcare industry.

The main features of the products in this range are their high reliability and the option of offering customised solutions. Our cold storage rooms are manufactured in compliance with the standards in force.

Characteristics of the range

- Quick and easy assembly
- Rounded inside corners
- Precise temperature control (luminous intensity and humidity on demand)
- Insulation material: polyurethane, polystyrene and mineral wool
- Direct and indirect cooling systems
- ATEX execution on demand
- Maximum fire resistance rating: A2s1d0.

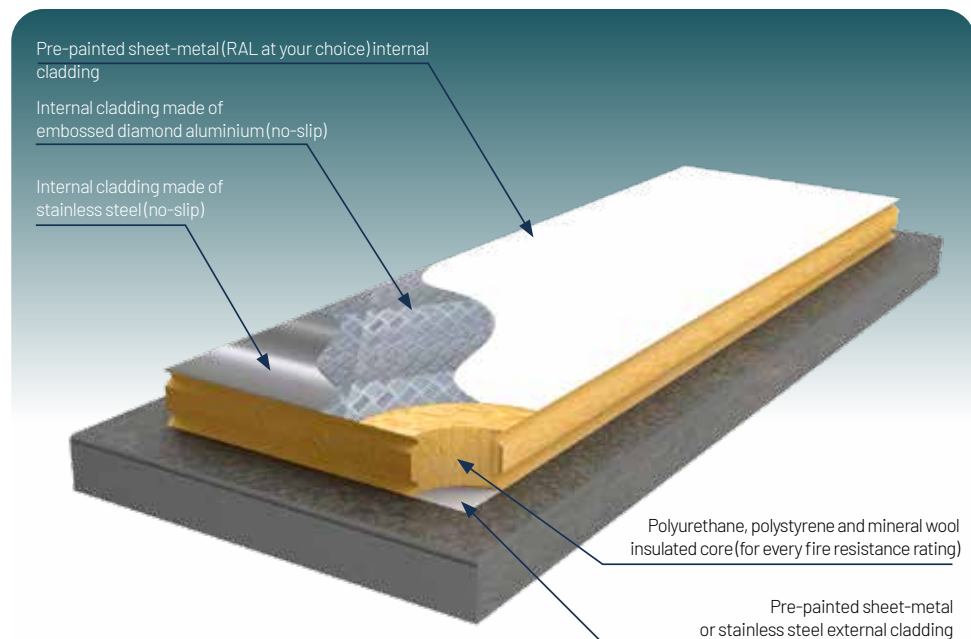

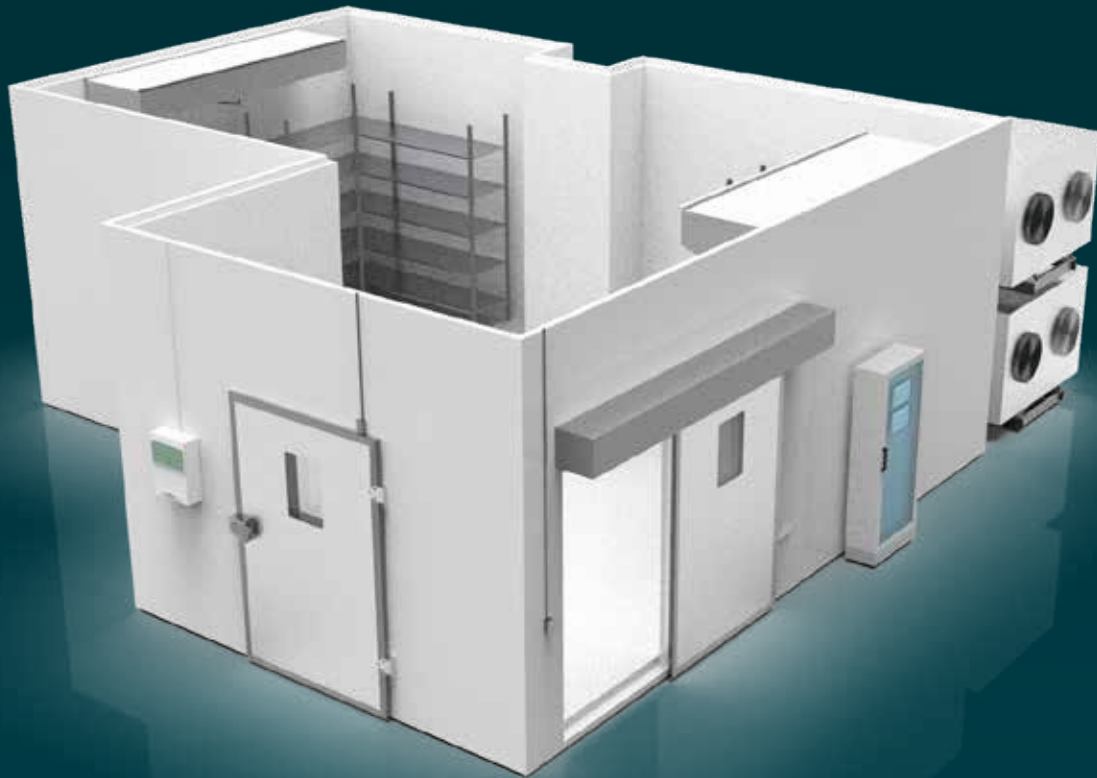

How a PE series prefabricated room is made

Insulated floors cladded in pre-painted sheetmetal or embossed diamond aluminium or no-slip stainless steel.

Our floors can bear even heavy loads such as those carried by lift trucks and forklifts. The floor is provided with a draining device to simplify cleaning and drain off fluid spills. The inside corners are rounded to easily remove filth.

The walls are made of modular panels with the following technical features:

- Core in expanded polyurethane, polystyrene or mineral wool.
- Pre-painted steel or stainless steel cladding (AISI 304 or 316). Panel thickness from 50 to 200 mm.

The service door is fitted with high-quality rubber or silicon gaskets and equipped with a microswitch to automatically switch off the fan when the door is opened.

There is a door on the outside with a handle with a key closing system, which can be opened in any case from the inside. Internal emergency button.

Manually or automatically opened sliding doors can be supplied on demand, complete with air wave safety devices.

The door frame is heated by a specific built-in electric heating element.

On demand, protective curtains in PVC can be installed on the doors to limit heat loss when opened.

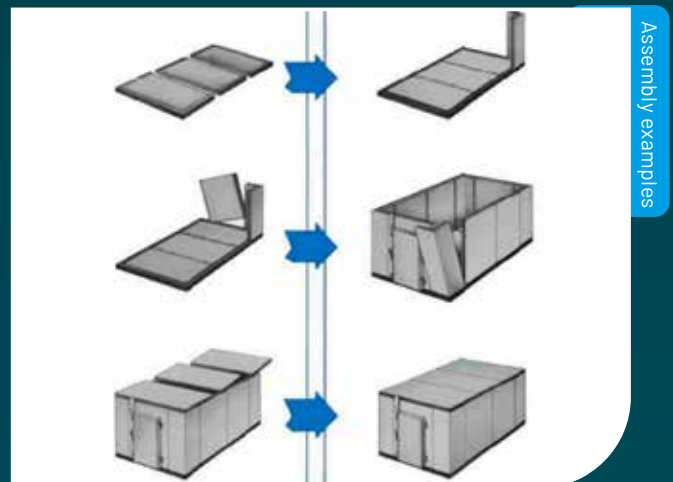

Assembly examples

REACH-IN PREFABRICATED

Modular freezers Temperature range: -20°C / -75°C

Dedicated customized solutions when medium storage capacity is required, with single capacity up to 10,000 liters.

Reach-in freezers available from -20°C to -75°C to be installed inside warehouses, wholesalers and pharmaceutical sites.

Properly designed for vaccine storage e completely customizable in terms of shape and modularity.

Characteristics of the range

- Redundant refrigeration systems
- Available volumes 4000 (3 doors) and 6000 liters (4 doors)
- Temperature uniformity: $\pm 5^{\circ}\text{C}$
- ACP7 controller
- Security and traceability in Bioguard access control
 - Only authorized users have access to the device
 - All accesses are tracked in terms of username, door open duration and door open event
- Connection to Cloud / Local monitoring software



Reach-in 6000 litres

Tecnologie del freddo per l'industria

Prefabricated cold storage room

WALK-IN Prefabricated Chambers down to -75°C

The central corridor is served
10 modules, 5 on each side.

Each module is equipped with 3 ports of
access, each of which allows
the entrance of a trolley.

The total capacity
of the plant is 30 trolleys.

The useful height of each module is 280 cm.
Each trolley has 4 shelves.

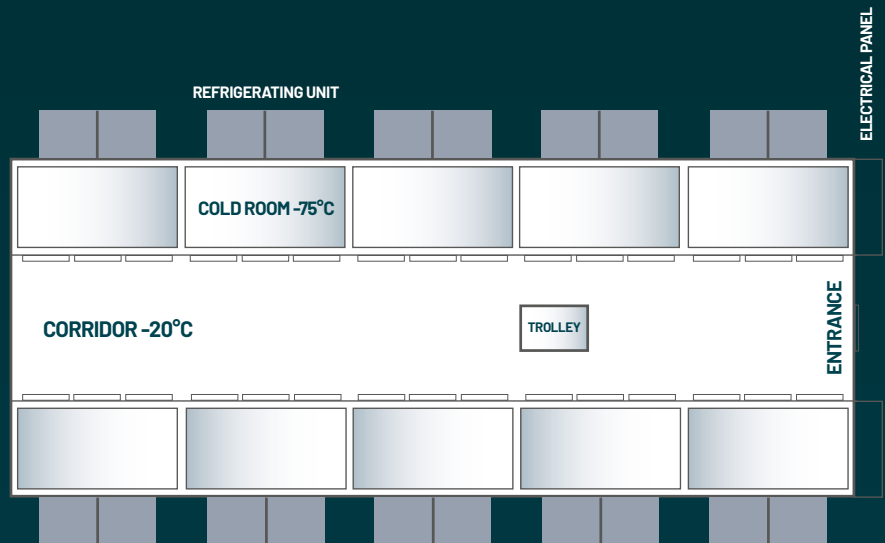

Two climatic chamber complex with photoperiod for controlled growth of insects

Construction of the prefabricated complex
through self-supporting modular type panels,
assemblable, without welding having the
following technical features:

- Temperature range +10 / +45°C
- Uniformity gradient of humidity values: +/- 5%
- Dew point: +5°C.
- Internal insulation with polyurethane injection (70 mm)
- Three swing doors, two of which with portholes
- Mechanical door interlock system for prevent simultaneous opening
- Common corridor between the two chambers

Ultra 3-Door Freezers

Temperature range:

-20°C / -40°C

Temperature uniformity:

±5°C

Ambient temperature of

exercise:

+5°C

Remote unit

condensing unit.

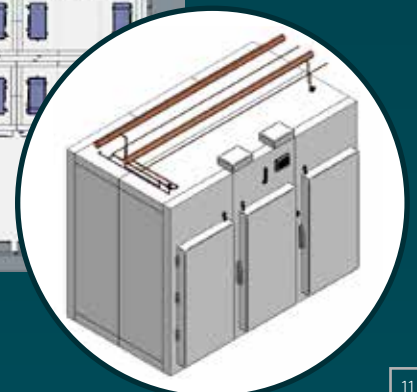

An advanced and reliable controller to make your work easier

ACP7: FULL CONTROL AT A GLANCE

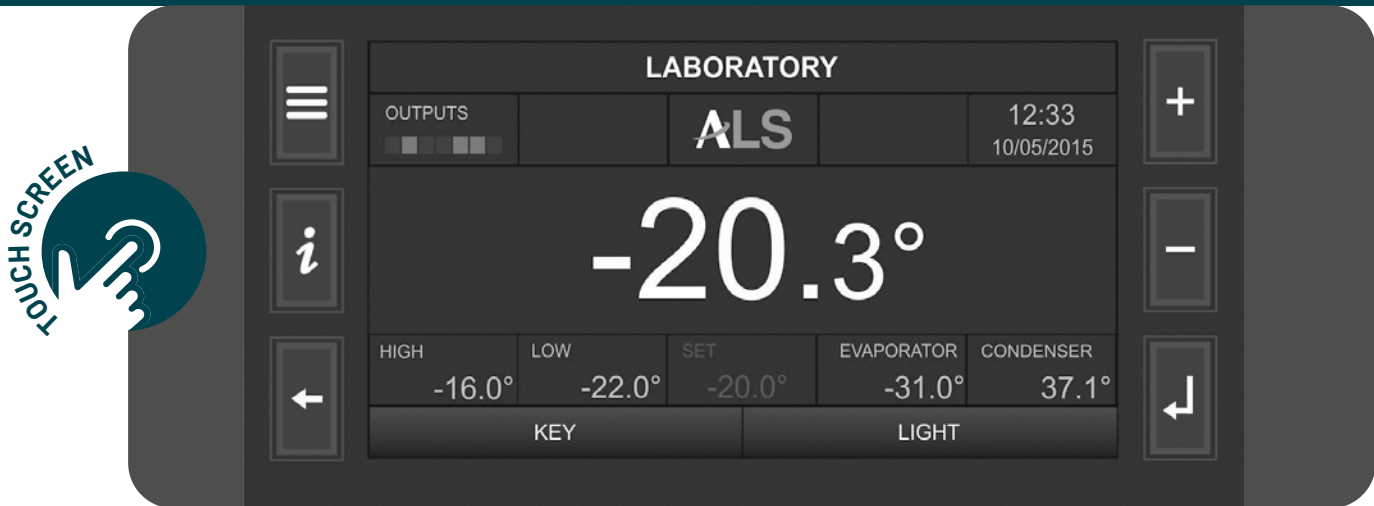

The last generation controller **ACP7**, developed by Angelantoni after years of experience and leveraging the latest technologies, guarantees high-performance, maximum safety and easy use.

The control electronics has three separate processors: one for the control system, one for the alarm section and one for communicating the detected data. Access to the parameters is password-protected with 3 privilege levels: users, service, administrator.

The **7-inch** display displays all key data on a single screen, allowing you to assess the operating status in real time. The ACP7 controller has innovative functions to optimise consumption and continuously monitor parameters.

The **REAL-TIME** function is used to display the daily temperature. This feature includes the events list and the record of the temperatures and operational variables sampled every 30 sec. for **10 years**. All values are stored and the event log files can be uploaded onto a local PC by means of the built-in **USB port** in the controller. The **ECOMODE** function enables the machine to an energysaving operating mode.

The **PERSONAL PASSWORD** allows you to regulate access to the controller and enable the editing functions of the user parameters.

MICROPLC TOUCH SCREEN



This PLC electronic programmer and touch screen user interface designed in ALS gives you the maximum flexibility in meeting the customer's requests. Able to program up to 1000 (one-thousand) cycles of 350 segments for temperature ramps (humidity and light on demand).

Unlimited possibility of recording temperature (and humidity) variations over time. Alarm log on table with date and time and total number of times triggered. The stored cycles, the records and alarm logs can be exported from Compact Flash to Pen Drive directly through the USB port on the control panel.

There is a buffer battery which allows you to store data even in case of a power failure.

Application examples

Stability test chamber



Fitotrone: controlled environment room, temperature and relative humidity adjustment, and photoperiod for quick agronomic screening

Angelantoni Life Science is a world leader in the market for refrigeration and biomedical equipment for use in laboratory and industrial processes, in particular for applications in healthcare, scientific and industrial research and



CYTOBOX

LAMINAR FLOW HOODS **STERIL LINE**

Safety, reliability and comfort

Steril designs, manufactures and sells a wide range of LAMINAR FLOW CABINETS, CONTAINMENT SOLUTIONS for operator and product protection, including biological safety cabinets, cytotoxic cabinets, horizontal and vertical laminar flow and Isolators.

THERMOSTATIC, CLIMATE AND PLANT GROWTH CABINETS **EKOC LINE**

Temperature range: -10°C / $+60^{\circ}\text{C}$

The **EKOC** series chambers are designed to control temperature in the range -10°C to $+60^{\circ}\text{C}$ and relative humidity between 20 and 90% (in the range $+10^{\circ}\text{C}/+50^{\circ}\text{C}$)
Three volumes available: 700, 900 and 1500 litres.

The **EKOCHL** series chambers are dedicated to stability and growth tests of plant species with controlled temperature, light and humidity.



EKOCHL 1500

the main industrial sectors. The aim is to produce innovative, quality systems that meet and exceed customer expectations in terms of performance and technical and design specifications.

FREEZERS AND ULTRA-LOW TEMPERATURE FREEZERS

NEXUS *green* LINE

Temperature range: -40°C / -80°C

In this regard, the Nexus *green* line is a natural evolution in the field of extremely low temperatures, which combines technological development and environmental sustainability.

- Natural refrigerants (HC)
- Inverter technology
- Energy savings (up to 30%) compared to fixed speed systems.
- Noiseless operation.
- High temperature stability.



NEXUS *green* 810



BULKFROST 1200 FH-EL

THERMOSTATIC CHAMBERS

BULKFROST LINE

Temperature range: -75°C / $+180^{\circ}\text{C}$

The thermostatic chamber allows the temperature inside the test chamber to be controlled. It delivers high performance, with a generous standard configuration and a large number of accessories to suit all our customers' requirements.

BENEFITS

The key feature, i.e. the main functionality of this range of models, is to allow the customer to set the temperature curve in a custom way, namely by modulate the rate of temperature descent and ascent with respect to the starting value, in order to optimise biological material freezing. As the biological world is highly diversified, the temperature curves for various types of sample will be equally diverse: with this line we are able to offer this essential quality.

Clean room:
cold storage room at -5°C
classified in class C.



Liquid nitrogen freezers,
for temperatures down to
 -180°C ,
horizontal and vertical
versions.



Temperature, humidity and
photoperiod climatic room
for the
growth of entomological
strains.

The iceman

The archaeological remains known as **"The Iceman"**, also called **"The Similaun Man"**, is definitely one of the most sensational and important archaeological discoveries of last century which UNESCO inserted in the World Heritage list.

It is the mummified body of a man who lived over **5,000 years ago**. The age was determined with the carbon 14 test in OXFORD, U.K., and ZURICH, Switzerland laboratories.

The importance of this discovery is that the body of a man who lived in the past, between the Neolithic period and the Copper Age, was preserved until today with his organism practically intact, since it was protected by ice. Many museums worldwide preserve human remains of different ages, even older than those of the Similaun Man. But it was a first time that a man was discovered with all his organs intact - skin, muscles, the brain, the face with blue eyes, the respiratory and digestive tracts and everything else.

The Similaun Man (also called "The Mummy" or "ÖTZI", from the ÖTZ valley near the place of discovery) is anatomically complete and substantially intact.

He was discovered casually in September 1991 by two German hikers, at an altitude of 3200 m, in the Alps between Austria and Italy.

One of the primary problems to be resolved after the discovery was how to preserve the remains. The system which we made was designed and installed by our AG division in Milan and is located in the new South Tyrol Museum of Archaeology set up by the Province of Bolzano by restructuring the austere building which housed the Bank of Italy in the same city of Bolzano, Italy. The essential core of the project is naturally Ötzi's room, where he will rest forever, in an environment which artificially and precisely reproduces the microclimate which had surrounded him in the Similaun Glacier for over 5000 years.

The technology which we developed in implementing Ötzi's preservation rooms open up to possible uses in the field of research, both industrial and scientific, at **temperatures below 0°C**, in controlled humidity **conditions** and in a **sterile environment** on materials and components, even electronics.



Save with Turboalgor

TURBOALGOR is an innovative start-up of the Angelantoni Group which patented an energy efficiency system in relation to the use of cold in refrigeration installations.

Turboalgor is the most cutting-edge solution to improve the energy efficiency of both new and old refrigeration installations, using a compressor turbo technology, from the automotive industry, aimed at increasing energy recovery through heat exchangers.

A revolutionary technological innovation for energy-saving, which marks a profound, dramatic change compared to any other energy saving solution existing in the cold storage sector such as **INVERTERS** or **ECONOMIZERS**. Turboalgor is ideal for cold rooms storing chemical, pharmaceutical and food products (ice cream and frozen goods), mass retailing, process cooling, etc.

The investment is paid back in a few years, without counting possible energy efficiency incentives.

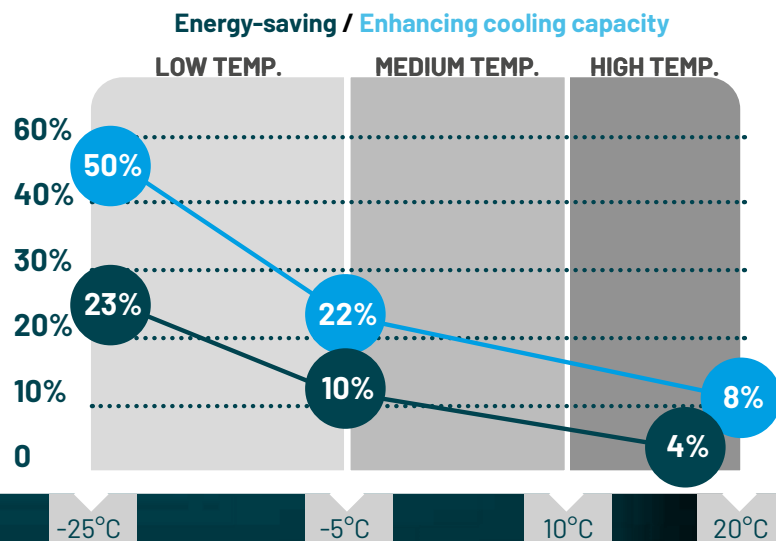

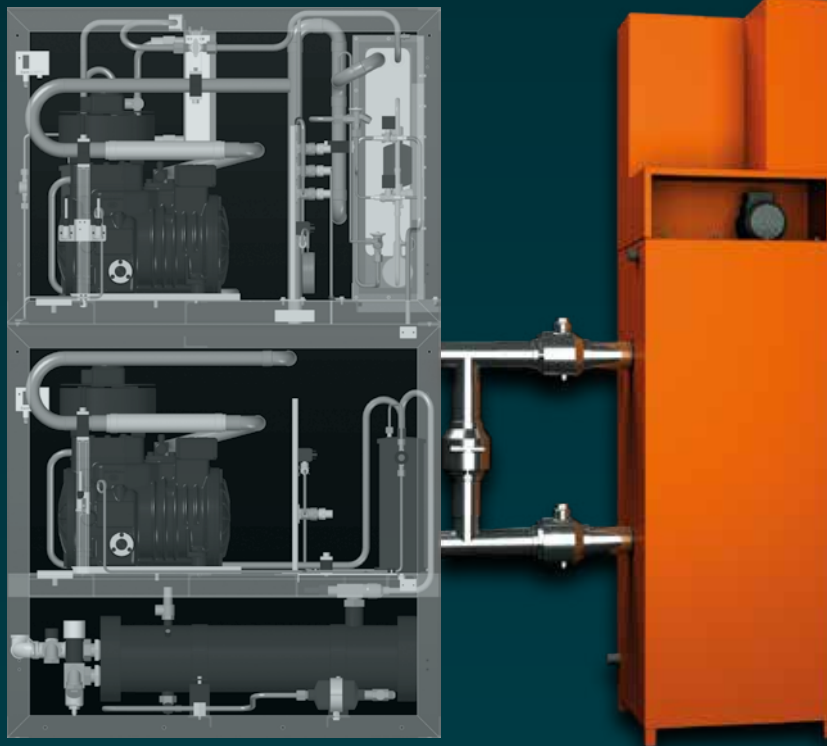

The refrigerant inside a conventional steam compression refrigeration system shows one weak spot: the expansion valve brings the refrigerant liquid from high to low pressure without making use of the energy potentially available. By inserting a heat exchanger (economizer) and a turbo-compressor like that used in the automotive industry, part of the energy which otherwise would be lost can be recovered, thus enhancing the cooling capacity of the installation.

The Turboalgor kit is therefore a combination of an economizer and a turbo-compressor inside a conventional steam compression refrigeration system. Turboalgor provides its customers with the most suitable KIT according to the technical specifications of their refrigeration plant, so as to maximise the advantages along the entire cold storage chain. The technology is suitable for industrial refrigeration systems (low temperature), for cooling systems (medium temperature) and for air-conditioning systems (high-temperature). Turboalgor divided its products into different combinations in terms of output (intended as

electrical power absorbed by the system) from 30 kW to 300 kW, and in terms of evaporation temperature, in order to supply the widest possible range of customers operating in the cold storage chain: from the food industry, to the retail sector, through to the chemical, pharmaceutical and refrigeration transport industry, as well as the server farm industry or any other company operating in the cold storage chain, capable of maximising the advantages of the kit.



AS

AG

STERIL

AIC

Angelantoni Life Science (ALS) is a world leader in the supply of refrigeration equipment and in the design of technological solutions in the biomedical sector, constantly engaged in innovation and safety, both biological and environmental.

AS brand provides for a wide range of refrigerators cabinets, ultra-low temperature freezers, blood banks refrigerators, freezers to preserve blood components, mortuary prefabricated rooms, stability tests and plant growth chambers, refrigerators and freezers for COVID-19 vaccines.

AG brand supplies standardized brine chilling units for pharmaceutical and chemical applications or pharma process, manual or automated solutions allow to reach -70°C for special walk-in chambers and shelters to storage vaccines or other farmaceutical products.

STERIL brand provides for equipment able to meet any product protection need, as well as the product, operator and environment safety requirements, for any level of concentration and for any kind of substance (horizontal and vertical laminar flow cabinets, biohazard and cytostatic safety cabinets, laminar flow pass boxes with UV, sanitized hydrogen peroxide pass boxes, weighing, sampling and dispensing cabinets and isolators designed in accordance with the latest international standards (GMP).

AIC brand provides Waster, and an automated treatment system for hospital and contaminated waste.



Angelantoni Plants



Angelantoni Life Science S.r.l.
MASSA MARTANA HEADQUARTERS
Località Cimacolle, 464 - 06056 Massa Martana (PG) - Italy
Ph. (+39) 075.89551
biomedical@angelantoni.it
MILAN BRANCH OFFICE
viale Monza, 291 - 20126 Milano (MI) - Italy
Ph. (+39) 02.939701.1



www.angelantonilifescience.it www.angelantoni.it